



RoseBuild

www.rosehantrade.com.tr

INDEX

JUICING EQUIPMENT

Manual Fruit Juicers

0101 Domestic Type Manual Fruit Juicer	7
0102 Professional Type Manual Fruit Juicer	8
0103 Pomegranate Type Manual Fruit Juicer	9

Automatic Orange Juicers

0203 38 With Glass Automatic Orange Juicer	11
0204-1101 38 With Tank And Stand Automatic Orange Juicer	12
0205-1101 38 Fresh With Stand Automatic Orange Juicer	13
0205-1107 38 Fresh & Stand With Double Trash Can	14
0206 28 Cafe Type Automatic Orange Juicer	15
0208 38 Cooler Model Automatic Orange Juicer	16

Automatic Juicers Technical Information	17-18-19
---	----------

Automatic Pomegranate Juicers

0601 32 With Glass Automatic Pomegranate Juicer	2
0602-1101 32 Automatic Pomegranate Juicer With Juice Tank & Stand	1
0603 Automatic Pomegranate Press	2

PREPARATION EQUIPMENT

1301 Vegetable Cutter	2
1302 Tomato Slicer	3
1306 Coring Spoon	2
1307 Walnut Opener	6
1308 Small Size Tomato Slicer	2
1313 Cheese Slicer	7
1316 Lemon Cutter	2
1319 Onion Flowering Cutter	8
1320 Mandoline Slicer	2
1321 Manual Potato Cutter	9
1323 Vegetable & Fruit Peeler	3
1324 Manual Melon Cutting Tool	0
1332 Manual Watermelon Cutting Tool	3
1327 Manual Watermelon Slicer	1
1325 Leaf Cutter	3
1326 Manual Pineapple Slicer	2
0801-1104 Pineapple Peeler Machine With Stand	3
0810 Pineapple Guillotine Cutter	3
1423 Pineapple Trio	3

1315 Fruit Cutter.....	4
1318 Vertical Tomato Slicer.....	4
1317 Combine Slicer.....	4
1330 Pizza Slicer.....	5
1305 Pneumatic Potato Cutter.....	4
1309 Pneumatic Melon Cutter.....	6
1310 Pneumatic Watermelon Cutter.....	4
0809 Pneumatic Pineapple Peeler Machine (With Stand).....	7
1701 Bread Oiler Tool.....	4
Electrical & Manual Can Openers	8
0702 Professional Type Electrical Can Opener Circle Cut.....	4
0703 Professional Type Electrical Can Opener Circle-Square Cut.....	4
0302 Professional Type Manual Can Openers.....	5
0303 Diamond Type Manual Can Openers.....	9
	5
 WASHING EQUIPMENT	6
0501 MT01 Sink Mounted Pre-Rinse Faucet.....	5
0502 MT02 Sink Mounted Pre-Rinse Faucet With Intermediate Tap.....	9
0503 MT03 Wall Mounted Pre-Rinse Faucet.....	6
0504 MT04 Wall Mounted Pre-Rinse Faucet With Intermediate Tap.....	0
0505 MT05 Mini Size Sink Mounted Pre-Rinse Faucet.....	6
0506 MT06 Mini Size Sink Mounted Pre-Rinse Faucet With Intermediate Tap.....	1
Deluxe Series	6
0507 MT01 Deluxe Sink Mounted Pre-Rinse Faucet.....	8
0508 MT02 Deluxe Sink Mounted Pre-Rinse Faucet With Intermediate Tap.....	6
0512 MT03 Deluxe Wall Mounted Pre-Rinse Faucet.....	8
0513 MT04 Deluxe Wall Mounted Pre-Rinse Faucet With Intermediate Tap.....	6
0509 MT05 Deluxe Mini Size Sink Mounted Pre-Rinse Faucet.....	4
0510 MT06 Deluxe Mini Size Sink Mounted Pre-Rinse Faucet With Intermediate Tap.....	8
Sink Mount Pot Filler	6
0511 Sink Mount Pot Filler.....	93
Retractable Models	7
0905 Retractable Pre-Rinse Faucet With Reel Hose (2 MT).....	9
0901 Retractable Pre-Rinse Faucet With Reel Hose (6 MT).....	8
0902 Retractable Pre-Rinse Faucet With Reel Hose (10 MT).....	7
0903 Retractable Pre-Rinse Faucet With Reel Hose (12 MT).....	6
0904 Retractable Pre-Rinse Faucet With Reel Hose (15 MT).....	7
Industrial Type Pot Washing Machine	7
1001 Industrial Type Pot Washing Machine.....	81
	8
	7



**JUICING
EQUIPMENT**

MANUAL FRUIT JUICERS





0102 PROFESSIONAL TYPE MANUAL FRUIT JUICER



It has a locking system both for strainer and bowl.

The diameter of the bowl, strainer and upper press is 10 cm.

There is a drip cup that prevents the juice from flowing out between juicing process.

It is designed to be used in places such as cafes, buffets and restaurants.



TECHNICAL SPECIFICATIONS

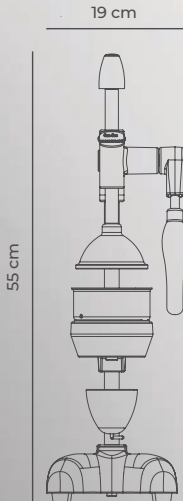

Product Code	: 0102
Weight	: 4,5 kg
Width	: 19 cm
Depth	: 30
Height	: cm 55



0103 POMEGRANATE TYPE MANUAL FRUIT JUICER



TECHNICAL SPECIFICATIONS

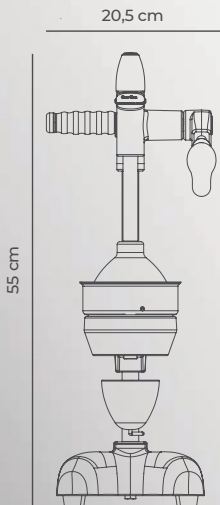

Product Code

: 0103

Weight

: 4,75 kg

Width

: 20,5 cm

Depth

: 30 cm

Height

: 55 cm

AUTOMATIC ORANGE JUICERS

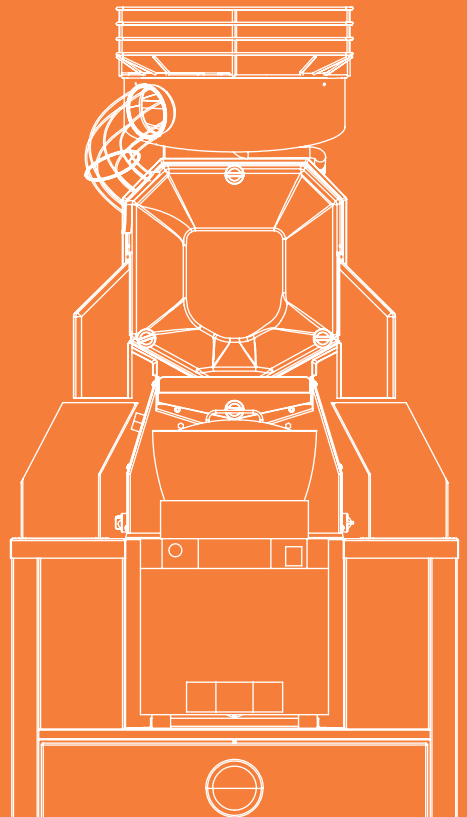



0203 38 WITH GLASS

AUTOMATIC ORANGE JUICER



The 38 with Glass Automatic Orange Juicer is used in various places like hotels, restaurants, markets, and more.

It's designed for juicing citrus fruits such as oranges, tangerines, and lemons in public settings.

It can squeeze 38 oranges per minute and has a 15 kg fruit storage chamber.

It uses a turning disc to rotate the oranges and make them fall into the feeding wire one by one.



TECHNICAL SPECIFICATIONS



Technical Specifications

: 0203

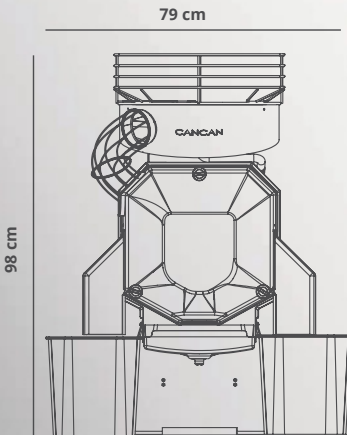

Orange Squeezing	:	38 Pcs/min.
Capacity Orange Diameter	:	Ø 6 - 8 cm
Orange Basket	:	15 kg
Motor	:	0,37 kw
Consumption	:	2,5 A
Power	:	220 - 230 V
Frequency	:	50 - 60 Hz
Weight	:	76 kg
Width	:	79 cm
Depth	:	58 cm
Height	:	98 cm



0204 - 1101 38 WITH TANK AND STAND

AUTOMATIC ORANGE JUICER



The 38 Automatic Orange Juicer with Tank is used in various places like hotels, restaurants, markets, malls, hospitals, dormitories, cafes, and universities.

It's designed for juicing citrus fruits such as oranges, tangerines, and lemons in public areas, squeezing 38 oranges per minute.

It features a 15 kg fruit storage chamber and a turning disc to rotate and feed oranges one by one.

It also has a 5-liter juice storage tank and a mobile stand with a 70 kg peel waste container.



TECHNICAL SPECIFICATIONS

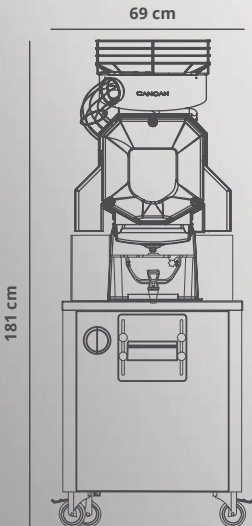

Technical Specifications

:0204 - 1101

Orange Squeezing	:	38 Pcs/min.
Capacity Orange Diameter	:	Ø 6 - 8 cm
Orange Basket	:	15 kg
Motor	:	0,37 kw
Consumption	:	2,5 A
Power	:	220 - 230 V
Frequency	:	50 - 60 Hz
Weight	:	117 kg
Width	:	69 cm
Depth	:	70 cm
Height	:	181 cm

***Mobile Stand is optional.**

0205-1101 38 FRESH WITH STAND AUTOMATIC ORANGE JUICER



The 38 Fresh Model Automatic Orange Juicer with a self-service tap is suitable for various places like hotels, restaurants, markets, malls, hospitals, dormitories, cafes, and universities.

It's designed for juicing citrus fruits like oranges, tangerines, and lemons in public areas, squeezing 38 oranges per minute.

It features a 15 kg fruit storage chamber and a turning disc to feed oranges one by one. The mobile stand also has a 70 kg peel waste container.



TECHNICAL SPECIFICATIONS

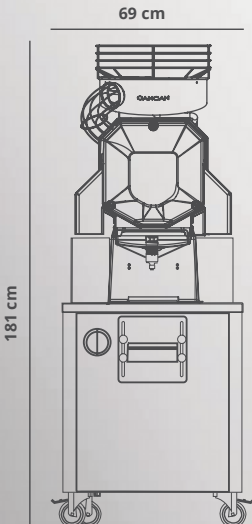

Technical Specifications

:0205 - 1101

Orange	Squeezing	: 38 Pcs/min.
Capacity Orange Diameter		: Ø 6 - 8 cm
Orange Basket		: 15 kg
Motor		: 0,37 kw
Consumption		: 2,5 A
Power		: 220 - 230 V
Frequency		: 50 - 60 Hz
Weight		: 117 kg
Width		: 69 cm
Depth		: 70 cm
Height		: 181 cm

*Mobile Stand is optional.



0205-1107 38 FRESH & STAND WITH DOUBLE TRASH CAN



The Automatic Orange Juicer with a self-service tap is perfect for hotels, restaurants, markets, malls, hospitals, dorms, cafes, and universities.

It's designed to quickly squeeze the juice from oranges, tangerines, and lemons in public places.

It can squeeze 38 oranges per minute and can hold up to 28 kg of fruit.

Thanks to a turning disc, it feeds oranges one by one.

The mobile stand has two 70 kg peel waste containers for easy disposal, and it comes with an easy-to-clean stainless strainer.

TECHNICAL SPECIFICATIONS

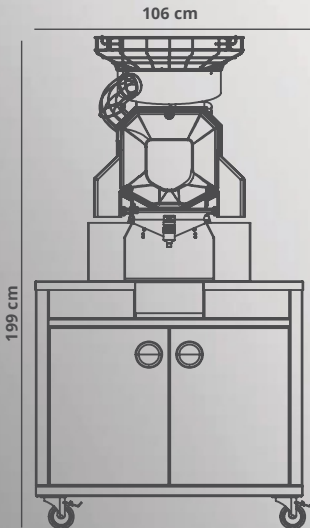

Technical Specifications

: 0205-1107

Orange	Squeezing	:38 Pcs/min.
Capacity Orange Diameter	:Ø 6 - 8 cm	
Orange Basket	:28 kg	
Motor	:0,37 kw	
Consumption	:2,5 A	
Power		:220 - 230 V
Frequency	:50 - 60 HZ	
Weight	:137 kg	
Width	:106 cm	
Depth	:94 cm	
Height	:199 cm	

* Mobile Stand is Optional.



0206 28 CAFE TYPE AUTOMATIC ORANGE JUICER



The Cafe-type Automatic Orange Juicer is ideal for a wide range of establishments, including hotels, restaurants, markets, shopping malls, hospitals, student dormitories, cafes, and universities.

Designed for juicing citrus fruits like oranges, tangerines, and lemons in public settings, it has a capacity to squeeze 28 oranges per minute.

This machine features a manually fed orange hopper that can store up to 7 kg of fruit.



TECHNICAL SPECIFICATIONS



Technical Specifications

: 0206

Orange Squeezing	: 28 Pcs/min.
Capacity Orange Diameter	: Ø 6 - 8 cm
Orange Basket	: 7 kg
Motor	: 0,25 kw
Consumption	: 2,5 A
Power	: 220 - 230 V
Frequency	: 50 - 60 Hz
Weight	: 45 kg
Width	: 73 cm
Depth	: 41,5 cm
Height	: 86,5 cm

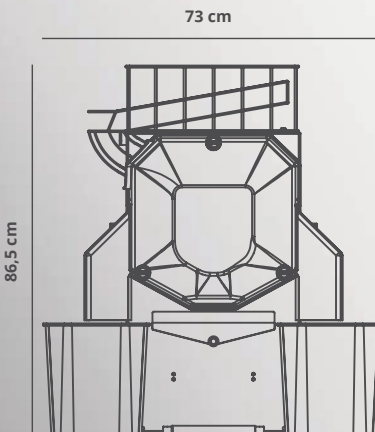



0208 38 COOLER MODEL AUTOMATIC ORANGE JUICER



The 38 Cooler Model Automatic Orange Juicer with a refrigerated tank is ideal for use in a variety of locations, including hotels, restaurants, markets, shopping malls, hospitals, student dormitories, cafes, and universities.

This machine is designed for efficiently extracting juice from citrus fruits such as oranges, tangerines, and lemons in public settings.

It boasts a remarkable capacity, squeezing

38 oranges per minute, and features a 15 kg fruit storage chamber.

With the help of a turning disc, it rotates the oranges, ensuring they fall into the feeding wire one by one.

The mobile stand is equipped with a 70 kg peel waste container.



TECHNICAL SPECIFICATIONS



Technical Specifications

: 0208

Orange Squeezing	:	38 Pcs/min.
Capacity Orange Diameter	:	Ø 6 - 8 cm
Orange Basket	:	15 kg
Motor	:	0,37 kw
Consumption	:	2,5 A
Power	:	220 - 230 V
Frequency	:	50 - 60 Hz
Weight	:	149 kg
Width	:	85 cm
Depth	:	81 cm
Height	:	181 cm

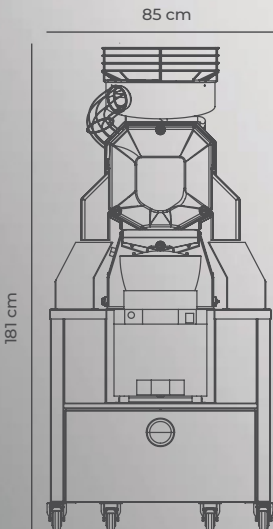

**Fruit Storage Basket**

Standard capacity of 15 kg and optional capacity of 28 kg fruit storage.

**Rotating Disk**

A system that makes the oranges falling into the feeding wire one by one by rotating the oranges.

**Large Volume Trash Can**

Pulp storage reservoir with up to 70 kg capacity.

**Large Feeding Wire**

Diameter of 10 cm side feeding wire.

**Cooler System**

Cooler Tank with a bottom cooling system that cools the juice equally until the last drop and with a juice storage capacity of 7 liters.

**Cleaning Pipe**

A system that cleans inside of the disk easily thanks to the pipe under the disk for a hygienic Squeezing Process.

**Front Cover with a****Safety Switch**

System that prevents operating of the machine while the front cover is open thanks to the safety switch, located on the front cover made of durable polycarbonate.

**Double Trash Can**

Double Trash Can with a capacity each of 70 kg.

**Juice Tank**

5 lt capacity juice tank according to food standards.

**Fruit Feeding Wire**

6 to 8 oranges storage capacity in the feeding wire.

**Self Service System**

System that starts the squeezing process when tap is pressed and stops when tap is released with the self service sensor tap made from AISI 304 stainless steel.

**Easily Cleanable Stainless Strainer**

All stainless strainer where you can clean the fruit pulp easily that strainer by pulling it right or left with one single movement.



REFERENCE CHART

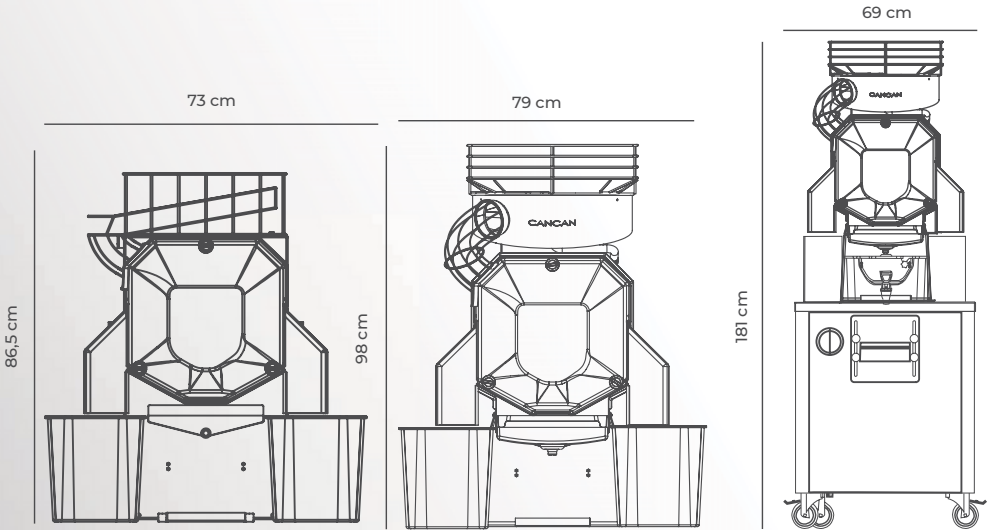

Technical Specifications : 0206

Orange Squeezing
 Capacity: 28 Pcs/ min.
 Orange Diameter: Ø 6 - 8 cm
 Orange Basket: 7 kg
 Motor: 0,25 kw
 Consumption: 2,5 A
 Power: 220 - 230 V
 Frequency: 50 - 60 Hz
 Weight: 45 kg
 Width: 73 cm
 Depth: 41,5 cm
 Height: 86,5 cm



Technical Specifications : 0203

Orange Squeezing
 Capacity: 38 Pcs/ min.
 Orange Diameter: Ø 6 - 8 cm
 Orange Basket: 15 kg
 Motor: 0,37 kw
 Consumption: 2,5 A
 Power: 220 - 230 V
 Frequency: 50 - 60 Hz
 Weight: 76 kg
 Width: 79 cm
 Depth: 58 cm
 Height: 98 cm



Technical Specifications : 0204 - 1101

Orange Squeezing
 Capacity: 38 Pcs/ min.
 Orange Diameter: Ø 6 - 8 cm
 Orange Basket: 15 kg
 Motor: 0,37 kw
 Consumption: 2,5 A
 Power: 220 - 230 V
 Frequency: 50 - 60 Hz
 Weight: 117 kg
 Width: 69 cm
 Depth: 70 cm
 Height: 181 cm

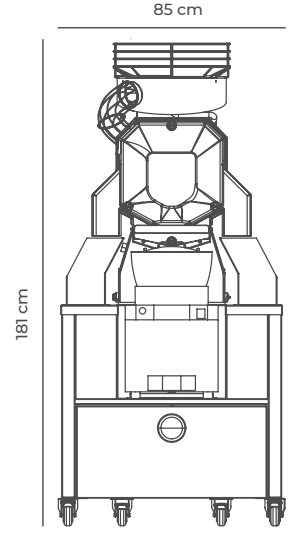
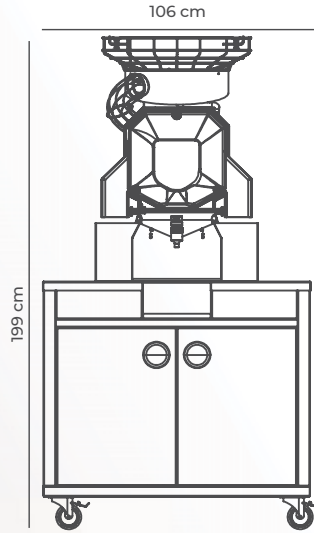
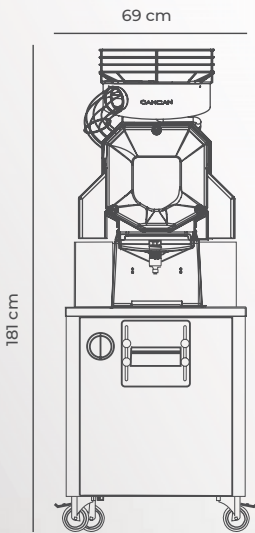

Technical Specifications :0205 - 1101

Technical Specifications : 0205-1107

Orange Squeezing Capacity: 38 Pcs/ min. Orange Squeezing Capacity: 38 Pcs/ min.
 Orange Diameter: Ø 6 - 8 cm Orange Diameter: Ø 6 - 8 cm
 Orange Basket: 15 kg Orange Basket: 28 kg
 Motor: 0,37 kw Motor: 0,37 kw
 Consumption: 2,5 A Consumption: 2,5 A
 Power: 220 - 230 V Power: 220 - 230 V
 Frequency: 50 - 60 Hz Frequency: 50 - 60 Hz
 Weight: 117 kg Weight: 137 kg
 Width: 69 cm Width: 106 cm
 Depth: 70 cm Depth: 94 cm
 Height: 181 cm Height: 199 cm

Technical Specifications : 0208

Orange Squeezing Capacity : 38 Pcs/
 Orange min. Ø 6 - 8
 Diameter: cm
 Orange Basket: 15 kg
 Motor : 0,37 kw
 Consumption : 2,5 A
 Power : 220 - 230 V
 Frequency : 50 - 60 Hz
 Weight : 149 kg
 Width : 85 cm
 Depth : 81 cm
 Height : 181 cm



0601 32 WITH GLASS AUTOMATIC POMEGRANATE JUICER



The Automatic Pomegranate Juicer with Glass is designed to squeeze pomegranate and grapefruits in places such as hotel, restaurant, school canteen, entertainment center and shopping malls.

This fully automatic machine; feeds, cuts and squeezes the pomegranates, removes the juice from the pulp and collects the juice. This product, capable of squeezing 32 pieces of pomegranates and grapefruits per minute, is fast and provides you clean and easy usage.



TECHNICAL SPECIFICATIONS

74 cm

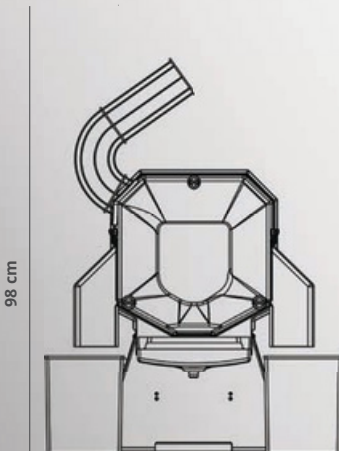

98 cm



Technical Specifications

: 0601

Pomegranate Squeeze	: 32 Pcs/min.
Pomegranate Diameter	: Ø 7 - 10 cm
Pomegranate Feeding Capacity	: 6-8 Pcs
Motor	: 0,55 kw
Consumption	: 2,5 A
Power	: 220 - 230 V
Frequency	: 50 - 60 Hz
Weight	: 68 kg
Width	: 74 cm
Depth	: 71 cm
Height	: 98 cm



0602-1101 32 AUTOMATIC POMEGRANATE JUICER, WITH JUICE TANK & STAND



The Automatic Pomegranate Juicer with Tank is designed to squeeze pomegranate and grapefruits in places such as hotel, restaurant, school canteen, shopping centers and supermarkets.

The fully automatic machine has 5 liter capacity of juice and the mobile stand offers 70 kg capacity of fruits peels storage.



TECHNICAL SPECIFICATIONS

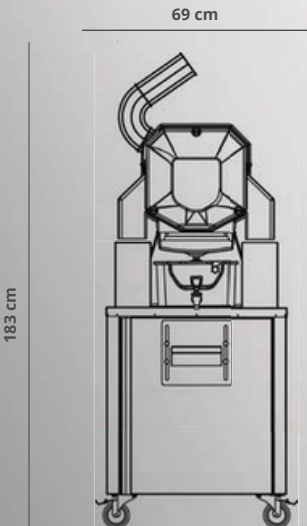

Technical Specifications

: 0602-1101

Pomegranate Squeeze:32 Pcs/min. **Pomegranate**

Diameter:Ø 7 - 10 cm **Pomegranate Feeding Capacity:**6-8

Pcs

Motor:0,55 kw

Consumption:2,5 A

Power:220 - 230 V

Frequency:50 - 60 Hz

Weight:109 kg

Width:69 cm

Depth:71 cm

Height:183 cm

* Mobile Stand is Optional.



0603 AUTOMATIC POMEGRANATE PRESS



Automatic Pomegranate Press is the smallest designed machine that can be used in places such as hotels, restaurants, commercial centers, entertainment and shopping centers, student dormitories, universities and fruit juice bars.

Its most important advantage is that it provides the opportunity to squeeze a wide variety of fruits with just a single machine. It enables the squeezing of fruits such as pomegranate, orange, grapefruit, lemon and tangerine very easily thanks to the hydraulic pressure system.

Thanks to the double filter system, it does not mix the fruit pulp into the fruit juice. It is very practical and easy to clean with its complete stainless body and stainless parts.



TECHNICAL SPECIFICATIONS



Technical Specifications

: 0603

Pressing Plate Size	: 13 x 24 cm
Cup Reservoir Height	: 17 cm
Fruit Squeezing Capacity	: 6 Pcs/
Fruit Diameter	: min
Fruit Reservoir	: Ø13 cm
Motor	: 7 kg
Consumption	: 0,55 kw
Power	: 3,4 A
Frequency	: 220 V
Weight	: 50 - 60 Hz
Width	: 50 kg
Depth	: 30 cm
Height	: 44 cm
	65 cm



PREPARATION EQUIPMENT



1301 VEGETABLE CUTTER



Designed for industrial kitchens in hotels, restaurants, and cafes, the vegetable cutter features a solid structure and sharp blades.

It ensures uniform cutting while preserving the freshness of fruits and vegetables, all without crushing them.

It enhances efficiency through its ergonomic design, delivering a smooth and effortless operation.



TECHNICAL SPECIFICATIONS

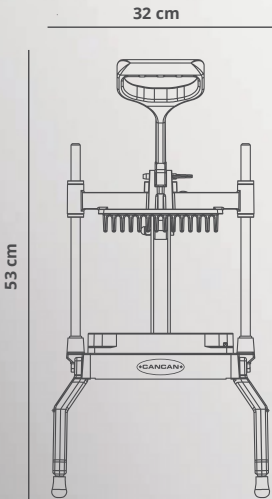

Blade Specifications

Product code :

1301-1

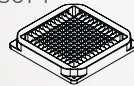

12,5 mm x 12,5 mm

1301-2

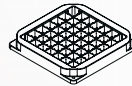

25 mm x 25 mm

1301-3

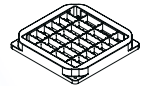

25 mm x 50 mm

Technical Specifications

: 1301

Weight

: 9,5 kg

Width

: 32

Depth

: cm

Height

: 43

Maximum lettuce diameter

: cm

53

cm

17 cm





1302 TOMATO SLICER



Made of first-class stainless steel material and reinforced with durable components, the tomato slicer is manufactured to withstand intensive use in industrial kitchens. With its serrated blades, the tomato slicer can easily cut through tough and unripe tomatoes, preserving their freshness and flavor.



TECHNICAL SPECIFICATIONS

Blade Specifications Product code :

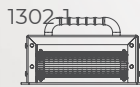

5 mm

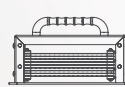

7 mm

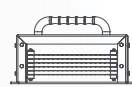

10 mm

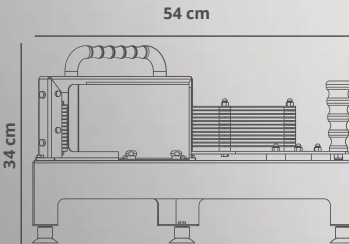

Technical Specifications : 1302

Weight : 10 kg

Width : 22 cm

Depth : 54 cm

Height : 34 cm

Maximum Tomato diameter : 9,5

cm



1306 CORING SPOON



The Coring Spoon, efficiently removes tomato stems in a single action, simplifying creative culinary tasks like tomato carving. This specialized tool facilitates quick and easy preparation of fresh tomatoes, making it a valuable addition to your kitchen utensils.



TECHNICAL SPECIFICATIONS

2,5cm



12 cm

Technical Specifications : 1306

Weight : 10 gr

Width : 2,5

Depth : cm

Height : 1,5 cm

12 cm



1307 WALNUT OPENER



The Walnut Opener is designed to effortlessly crack the tough shells of walnuts. It serves as a practical and secure alternative to traditional methods, saving both time and energy while preserving the natural flavor of the walnuts when presented on the dish.



TECHNICAL SPECIFICATIONS

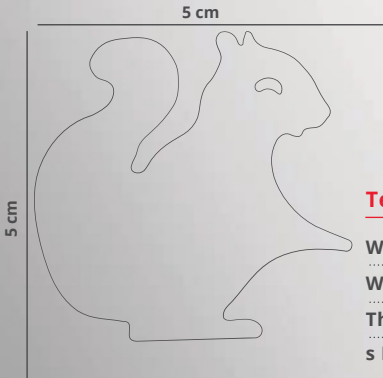

Technical Specifications		: 1307
Weight	:	10 gr
Width	:	5 cm
Thickness	:	0,1
Height	:	5 cm
Depth	:	cm



1308 SMALL SIZE TOMATO SLICER



Small Size Tomato Slicer is used in industrial kitchens such as hotels, canteens, cafes and restaurants. Its sharp, serrated blades delicately slice tomatoes, preserving their taste without causing any breakage. Moreover, its ergonomic design allows for maximum efficiency in compact kitchen spaces.



TECHNICAL SPECIFICATIONS

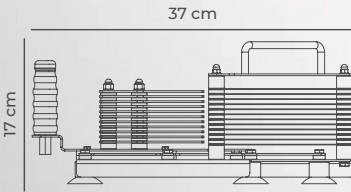

Blade

Specifications

Product code:

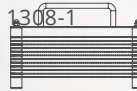

5 mm

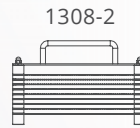

7 mm

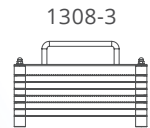

10 mm

Technical Specifications

: 1308

Weight : 3,70 kg

Width : 16 cm

Depth : 37 cm

Height : 17 cm

Maximum tomato diameter : 9,5 cm





1313 CHEESE SLICER



The Cheese Slicer, suitable for industrial kitchens like those in hotels, restaurants, cafes, facilitates effortless cutting of various cheese types and eggs, ensuring they remain intact. Its ergonomic design adds to its functionality, making it easy to use.



TECHNICAL SPECIFICATIONS

Blade

Specifications

Product code:

1313-2

1313-3



5 mm



7 mm



10 mm

Technical Specifications

: 1313

Weight : 3,90 kg

Width : 23 cm

Depth : 40 cm

Height : 11 cm

Table size : 16,5 x 9,1 cm

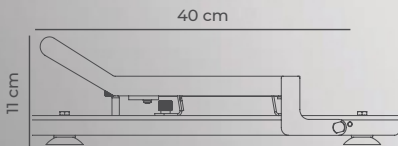



1316 LEMON CUTTER



The Lemon Cutter, designed for quick and precise lemon slicing, is employed in various establishments such as hotels, restaurants, bars, and cafes. Its sharp blades enhance the visual appeal of lemon presentations.



TECHNICAL SPECIFICATIONS

Blade Specifications Product code:

1316-1 1316-2



4 Slices



6 Slices

1316-3



8 Slices

1316-4



12 Slices

1316-5

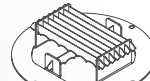

6 Half Slices

1316-6

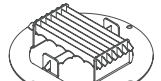

12 Half Slices

48 cm

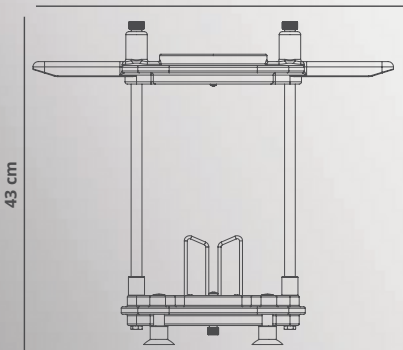

Technical Specifications

	: 1316
Weight	: 3,4 kg
Width	: 48 cm
Depth	: 18 cm
Height	: 43 cm
Maximum lemon diameter	: 8 cm





1319 ONION FLOWERING CUTTER



The precisely designed blades of the onion flower cutter allow the onion to open into a flower shape, increasing versatility and efficiency in the menu with different presentation types.



TECHNICAL SPECIFICATIONS

Blade

Specifications

Product code :

1319

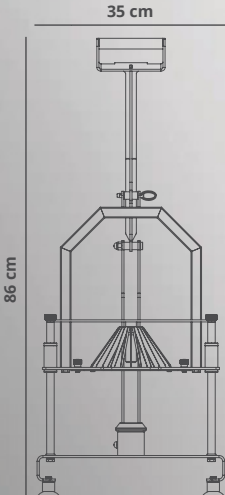
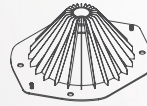

Technical Specifications

: 1319

Weight

: 9,5 kg

Width

: 35 cm

Depth

: 26 cm

Height

: 86 cm

Maximum onion diameter

: 10 cm





1320 MANDOLINE SLICER



The Mandoline Slicer, used in industrial kitchens, accurately slices fruits and vegetables into uniform sizes with its sharp serrated blades. It streamlines kitchen tasks by providing an adjustable slicing range, from 1.5 mm to 6.5 mm.



TECHNICAL SPECIFICATIONS

48 cm

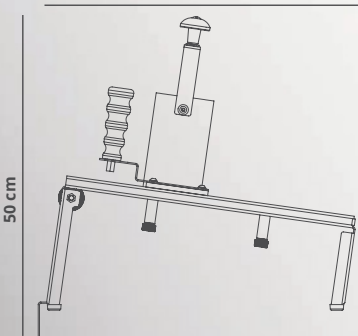

50 cm

Blade Specifications

Product code : 1320

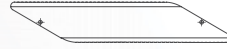

5 cm x 27,5 cm

Technical Specifications

	: 1320
Weight	: 4 kg
Width	: 24,5 cm
Depth	: 48 cm
Height	: 50 cm
Maximum vegetable diameter	: 8 cm

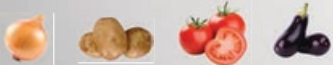



1321 MANUAL POTATO CUTTER



In industrial kitchens, it finds frequent use for rapidly and consistently cutting potatoes. Different blade options ensure the creation of uniformly sized potato slices.



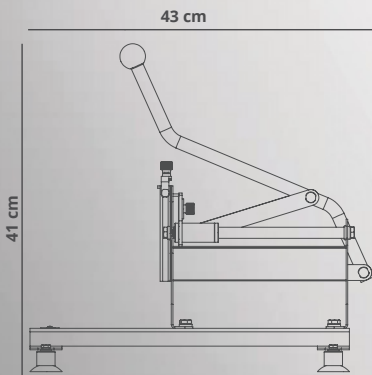

TECHNICAL SPECIFICATIONS



Blade

Specifications

Product code:	1321-2	1321-3
1321-1		
	6 mm x 6 mm	10 mm x 10 mm
		13 mm x 13 mm

Technical Specifications

Weight	: 4,7 kg
Width	: 20 cm
Depth	: 43 cm
Height	: 41 cm
Maximum potato diameter	: 8 cm





1323 VEGETABLE & FRUIT PEELER



The Peeling Machine, suitable for use in various settings including hotels, restaurants, cafes, and industrial kitchens, efficiently peels fruits and vegetables. This machine combines practicality and efficiency, accelerating and standardizing the peeling process.



TECHNICAL SPECIFICATIONS

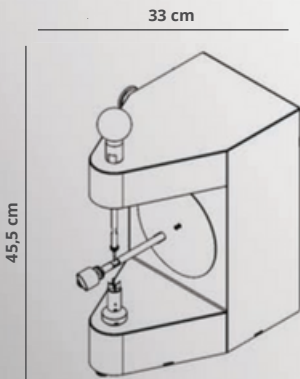

Technical Specifications		: 1323
Weight		: 11,3 kg
Width		: 24 cm
Depth		: 33 cm
Height		: 45,5 cm
Thinner Peels (Setting 1)		: 8 pcs/min
Thicker Peels (Setting 2)		: 4 pcs/min
Maximum	fruit-vegetable	: 11,5 cm
diameter	Watt Power	: 35 Watt
Amp		: 2,9 Aa
Voltage		: 220-250 VAC, 50-60 HZ
IP		: IPx4

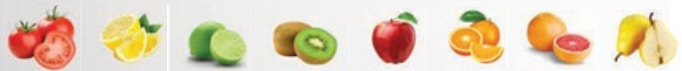



1324 MANUAL MELON CUTTING TOOL



Manual Melon Cutting Tool, suitable for use in industrial kitchens, effortlessly creates uniform slices with its exceptionally sharp blades.



TECHNICAL SPECIFICATIONS

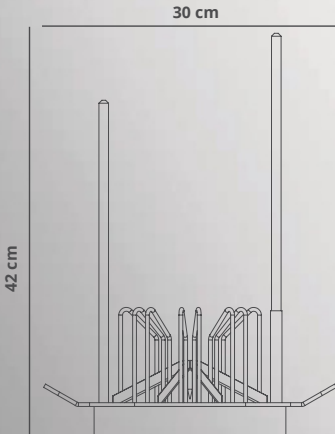

Blade

Specifications

Product code:

1324-2

1324-3



4 slices



6 slices

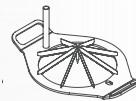

8 slices

Technical Specifications

: 1324

Weight : 2,5 kg

Width : 30 cm

Depth : 20 cm

Height : 42 cm

Maximum melon diameter : 15 cm





1327 MANUAL WATERMELON SLICER



Manual Watermelon Slicer makes slicing watermelons and melons easy.

This machine simplifies the cutting process, dividing the product into equal slices and enhancing its visual appeal for presentations.

It is commonly used in various settings such as markets, restaurants, cafes, hotels, and industrial kitchens.



TECHNICAL SPECIFICATIONS

Blade

Specifications

Product code :

1327

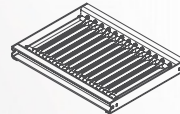

15 mm

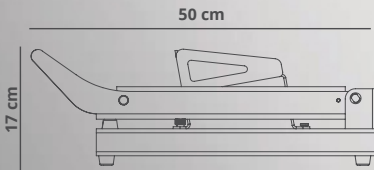

Technical Specifications

: 1327

Weight

: 16,7 kg

Width

: 49 cm

Depth

: 50 cm

Height

: 17 cm

Maximum length of fruit

: 37,5 cm x 7,5 cm





1325 LEAF CUTTER



Leaf Cutter, used in industrial kitchens such as hotels, restaurants, fast food establishments, and catering services, has a cutting thickness of 1.5mm.

The blade is constructed from stainless steel and complies with food safety standards.

By cutting fruits and vegetables into leaf and shapes, it enhances the visual appeal and taste of food presentations.



TECHNICAL SPECIFICATIONS

Blade

Specifications

1325

Product code :

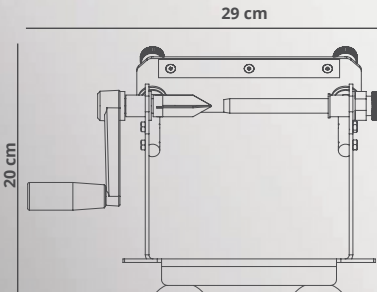
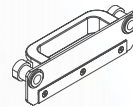

Technical Specifications

: 1325

Weight	:	2,3 kg
Width	:	29 cm
Depth	:	21 cm
Height	:	20 cm
Maximum cutting diameter	:	15 cm
Maximum cutting length	:	12 cm

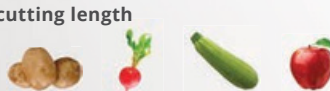



1326 MANUAL PINEAPPLE SLICER



Used in supermarkets, hotels, restaurants, and grocery stores, a manual pineapple slicer helps to slice pineapples into equal pieces.

Thanks to its functional design and sharp blades, it quickly and effectively slices the fruit.



TECHNICAL SPECIFICATIONS

Blade

Specifications

Product code :

1326

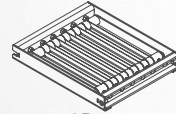

15 mm

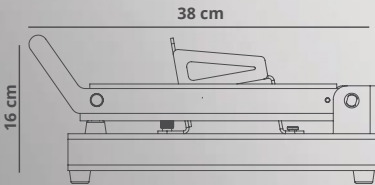

Technical Specifications

: 1326

Weight

: 8,4 kg

Width

: 27 cm

Depth

: 38 cm

Height

: 16 cm





0801-1104 PINEAPPLE PEELER MACHINE WITH STAND

The Pineapple Peeler is designed to effortlessly remove the peel and core of the pineapple in a single motion, making it ideal for use in hotels, restaurants, shopping malls, and grocery stores.

The stainless steel stand that has two options, with and without shelves, is designed for storage of the pineapples.



TECHNICAL SPECIFICATIONS

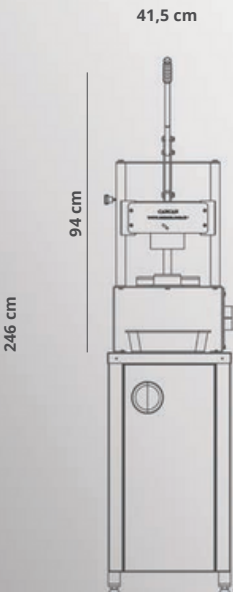

Blade Specifications

Product code :

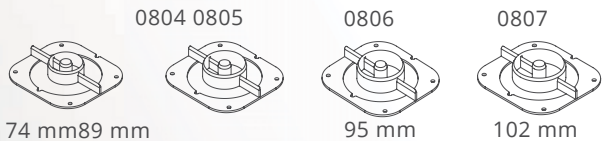

74 mm 89 mm

0806

95 mm

0807

102 mm

Pieces per box

10-12 pcs. 8-10 pcs.

6-8 pcs.

5-6 pcs.

Technical Specifications

: 0801-1104

Weight : 31 kg

Width : 41,5 cm

Depth : 65 cm

Height : 246 cm

Machine Weight : 13 kg

Stand Weight : 18 kg

Stand is Optional

